

PERFORATION RECONDITIONER SET

Do you have motion picture
shrunk films with missing perforations?

You need to replicate the missing perforations
but you want to keep correct distance
between the perforations?

HERE IS THE SOLUTION!

With this set of tools you will be quickly able to:

- 1 - Apply some regular and neutral splicing tape to reproduce the original film border giving back strength to the film support itself.
- 2 - Measure the new aged and then reduced perforation distance.
- 3 - Replicate the perforations on the applied tape, cloning the new shrunken distance so to keep the same pitch on the whole film length.

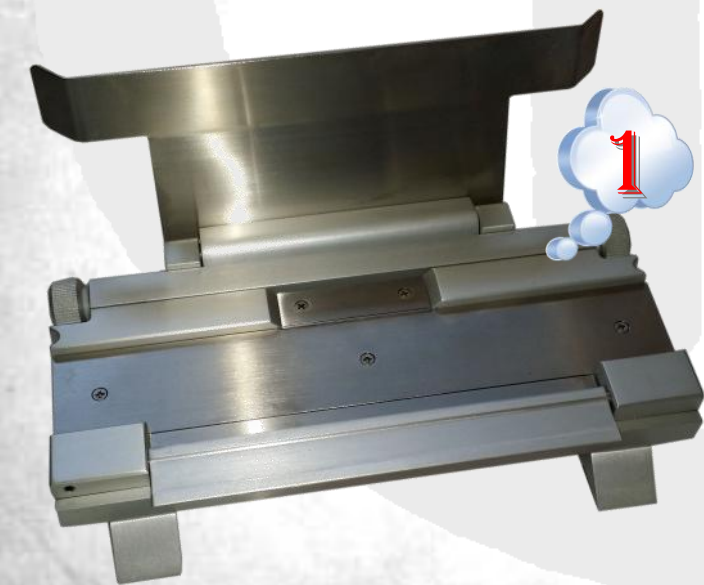

Demo clip



4700 Chase, Lincolnwood
Illinois U.S.A. 60712-1689
Phone: 800-323-7520 or 847-677-3000
Fax: 800-784-6733 or 847-677-1311
E-mail: sales@rtico.com Web: www.rtico.com



CIR S.r.l. Strada Prov.le per Tolfa km 0,700
00050 Santa Severa (Roma) - ITALY
Phone: +390766570008 Fax: +390766571390
Email: cir-srl@cir-srl.com
Web: www.cir-srl.com



PERFORATION RECONDITIONER SET

LIGHT

Do you have motion picture

shrunk films with missing perforations?

You need to replicate the missing perforations
but you want to keep correct distance
between the perforations?

HERE IS THE LIGHT SOLUTION!

With this "LIGHT" approach and set of tools you will:

1 - Apply some regular and neutral splicing tape to reproduce the original film border of the damaged side, giving back strength to the film support itself.

2 - Replicate the perforations on the applied tape, punching it through the provided tool that will align the puncher having the opposite correct perforation as reference.

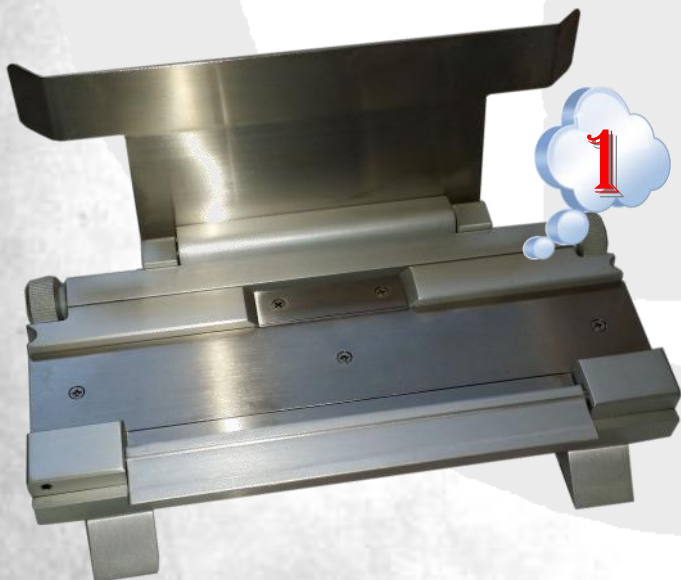

4700 Chase, Lincolnwood
Illinois U.S.A. 60712-1689
Phone: 800-323-7520 or 847-677-3000
Fax: 800-784-6733 or 847-677-1311
E-mail: sales@rtico.com Web: www.rtico.com



CIR S.r.l. Strada Prov.le per Tolfa km 0,700
00050 Santa Severa (Roma) - ITALY
Phone: +390766570008 Fax: +390766571390
Email: cir-srl@cir-srl.com
Web: www.cir-srl.com

